

THIS DOCUMENT IS THE PROPERTY OF
KEYSTONE ELECTRONICS CORP. AND
SHALL NOT BE REPRODUCED, DISTRIBUTED
OR USED AS A BASIS FOR MANUFACTURE
WITHOUT PRIOR WRITTEN PERMISSION
FROM KEYSTONE ELECTRONICS CORP.

TOP TOOL
P/N 1715

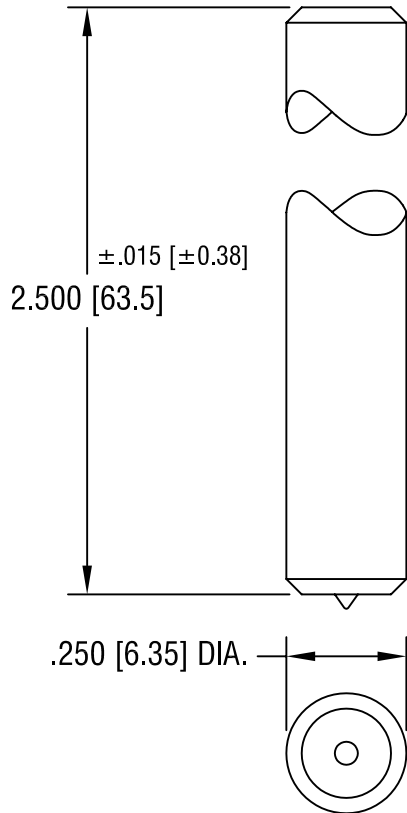

BOTTOM TOOL
P/N 1326

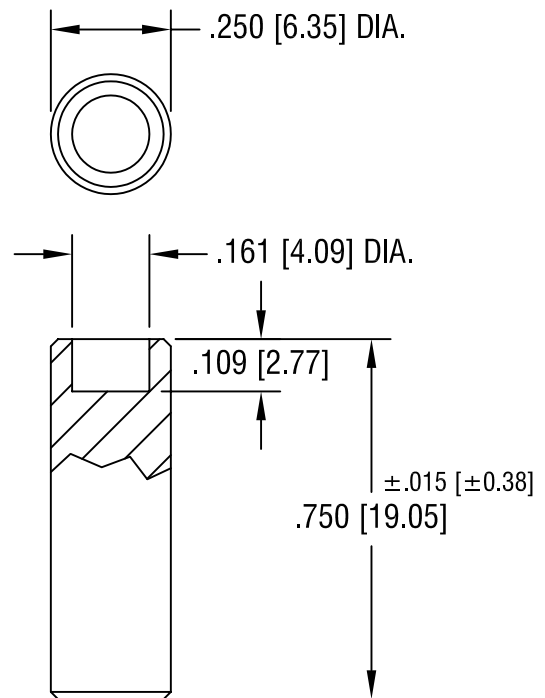

KEYSTONE ELECTRONICS CORP.

ASTORIA, N.Y. 11105-2017

PART NAME

SWAGE STAKING TOOL

MATERIAL

C.R.S.

FINISH

ZINC PLATE

DRN BY

BOONE

DATE

8.6.07

APP'D

LN

SCALE

2.5X

TOLERANCES

INCH [MM]

DECIMAL $\pm .005$ [± 0.15]

ANGULAR $\pm 1^\circ$
UNLESS OTHERWISE SPECIFIED

CODE

DWG NO.

C/M

TL-19

DATE

DESCRIPTION

REV.