

THIS DOCUMENT IS THE PROPERTY OF KEYSTONE ELECTRONICS CORP. AND SHALL NOT BE REPRODUCED, DISTRIBUTED OR USED AS A BASIS FOR MANUFACTURE WITHOUT PRIOR WRITTEN PERMISSION FROM KEYSTONE ELECTRONICS CORP.

REQUIRED SPACING FOR 'AAA' CLIP

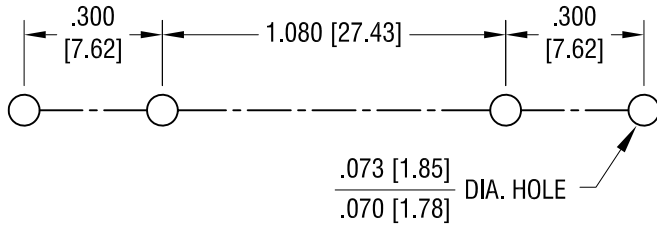

ACTUAL SIZE

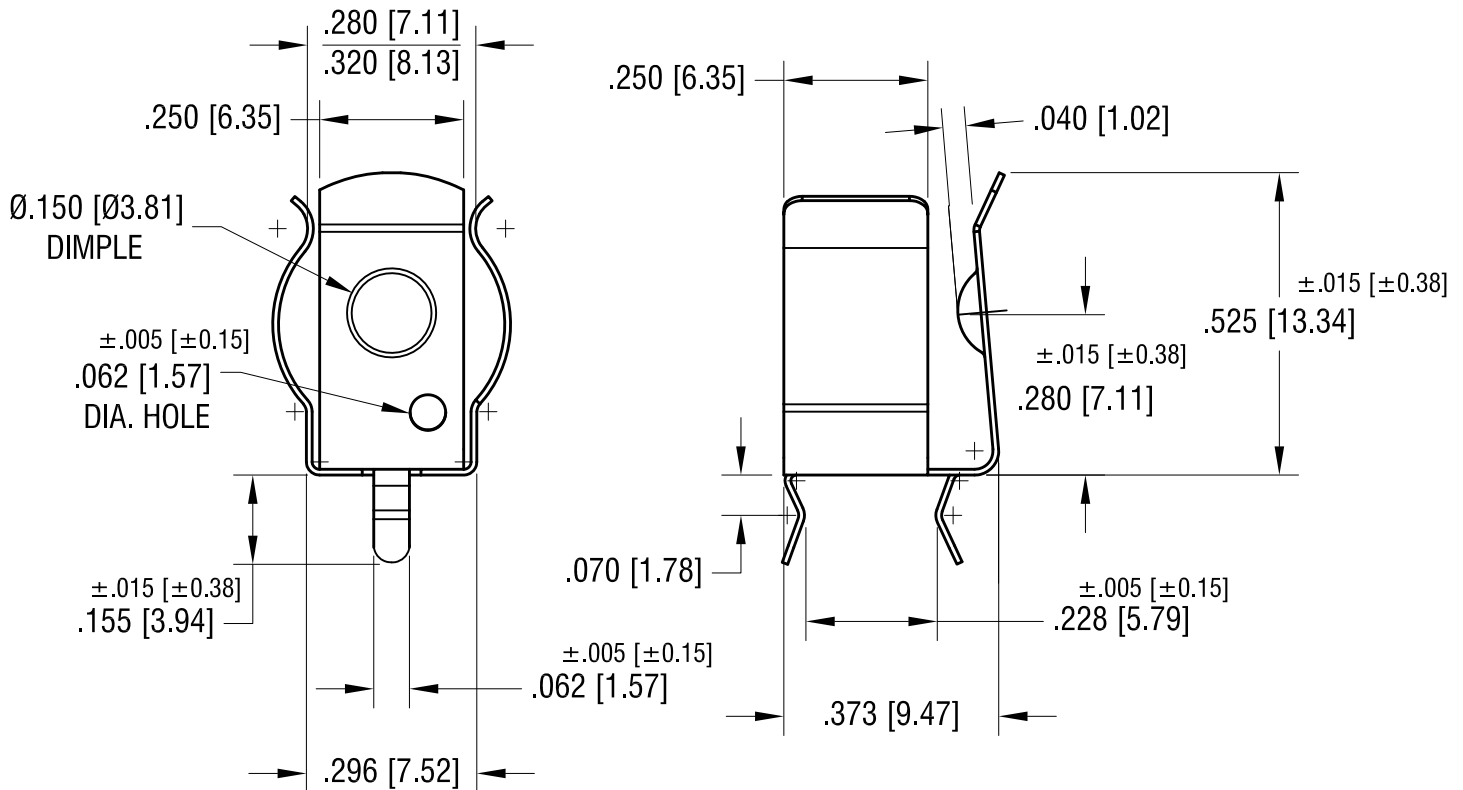
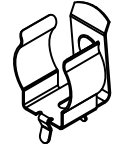

NOTE:

1. HEAT TREAT TO SPRING TEMPER.

KEYSTONE ELECTRONICS CORP.

www.keyelco.com • NEW HYDE PARK NY 11040 • Tel (516)328-7500

PART NAME		'AAA'-'N' PC BATTERY CLIP	
MATERIAL		.010 [0.25] TH'K ANNEALED SPRING STEEL	
FINISH		DRN BY	DATE
TIN NICKEL PLATE		BOONE	2.03.98
		APP'D	SCALE
		RH	3X
TOLERANCES	INCH [MM]	CODE	DWG NO.
DECIMAL	± .010 [± 0.25]	C	82
ANGULAR	± 1°		
UNLESS OTHERWISE SPECIFIED			

1.30.25	NO CHANGES TO PART.	T
10.06.16	CHANGE AS PER ECR 16-063.	R
DATE	DESCRIPTION	REV.