

THIS DOCUMENT IS THE PROPERTY OF KEYSTONE ELECTRONICS CORP. AND SHALL NOT BE REPRODUCED, DISTRIBUTED OR USED AS A BASIS FOR MANUFACTURE WITHOUT PRIOR WRITTEN PERMISSION FROM KEYSTONE ELECTRONICS CORP.

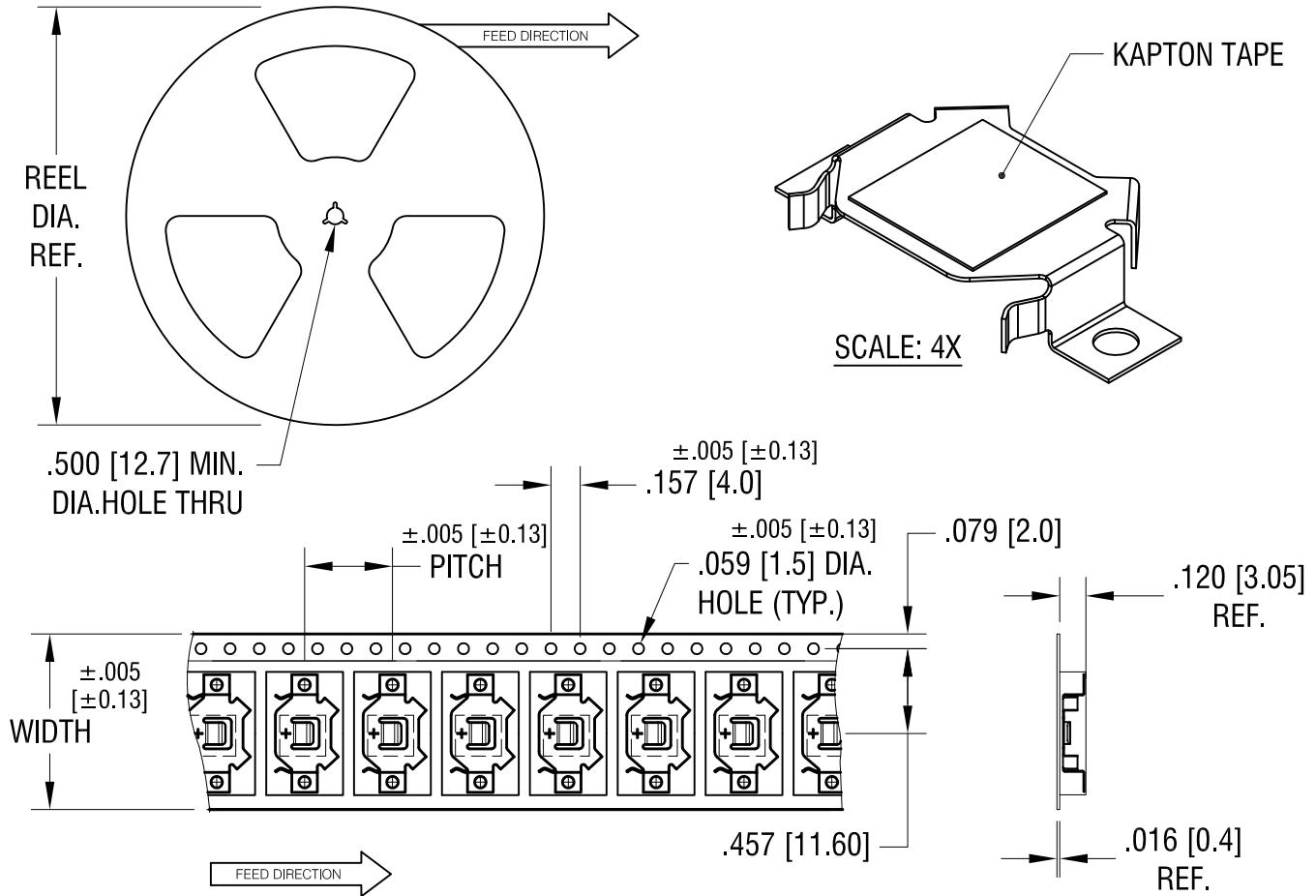

NOTES:

TAPE AND REEL SPECIFICATIONS:

1. TAPE:

MAT'L - ALL CONDUCTIVE POLYSTYRENE CARRIER
 ANSI/EIA-481 STANDARD
 .945 [24.0] WIDE; .473 [12.00] PITCH

2. REEL:

13.0 [330.2] DIA. 1500 PIECES OF
 PART NO. 3030 PER REEL.

3. KAPTON TAPE TO BE APPLIED TO TOP

SURFACE OF EACH RETAINER FOR VACUUM PICK AND PLACE

| | | | |
|---|-----------------|---------------------|----------------|
| KEYSTONE ELECTRONICS CORP. | | | |
| www.keyelco.com • ASTORIA, N.Y. 11105-2017 • Tel (718) 956-8900 | | | |
| PART NAME | | SM RETAINER ON TAPE | |
| MATERIAL | | AS NOTED | |
| FINISH | | DRN BY | DATE |
| AS NOTED | | NT | 8.05.16 |
| | | APP'D | SCALE |
| | | LN | X |
| TOLERANCES | INCH [MM] | CODE | DWG NO. |
| DECIMAL | ± .015 [± 0.38] | C | 3030KTR |
| ANGULAR | ± 1° | | |
| UNLESS OTHERWISE SPECIFIED | | | |

| | | | |
|------|-------------|------|--|
| DATE | DESCRIPTION | REV. | |
|------|-------------|------|--|

THIS DOCUMENT IS THE PROPERTY OF KEYSTONE ELECTRONICS CORP. AND SHALL NOT BE REPRODUCED, DISTRIBUTED OR USED AS A BASIS FOR MANUFACTURE WITHOUT PRIOR WRITTEN PERMISSION FROM KEYSTONE ELECTRONICS CORP.

MOUNTING PAD LAYOUT

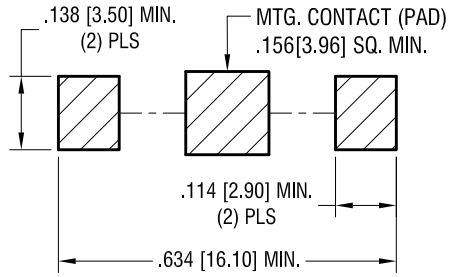

ACTUAL SIZE

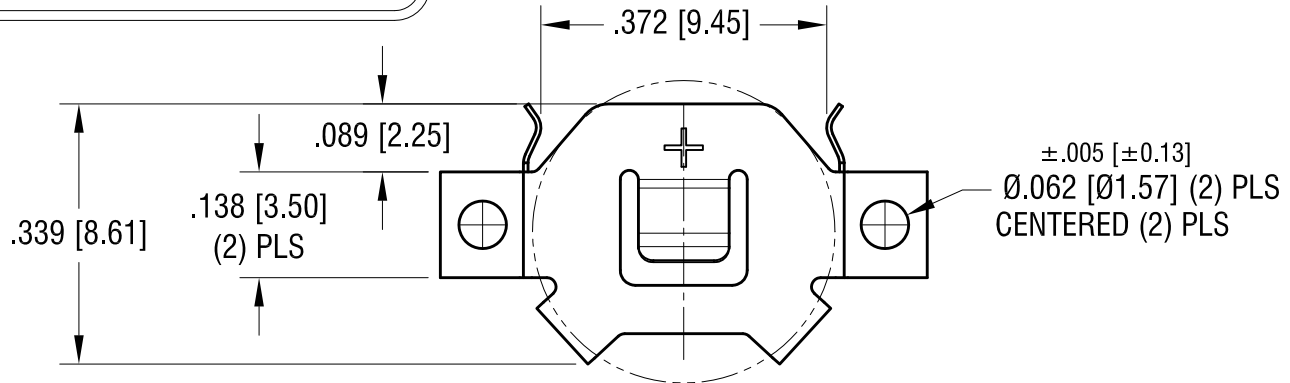

SECTION A-A

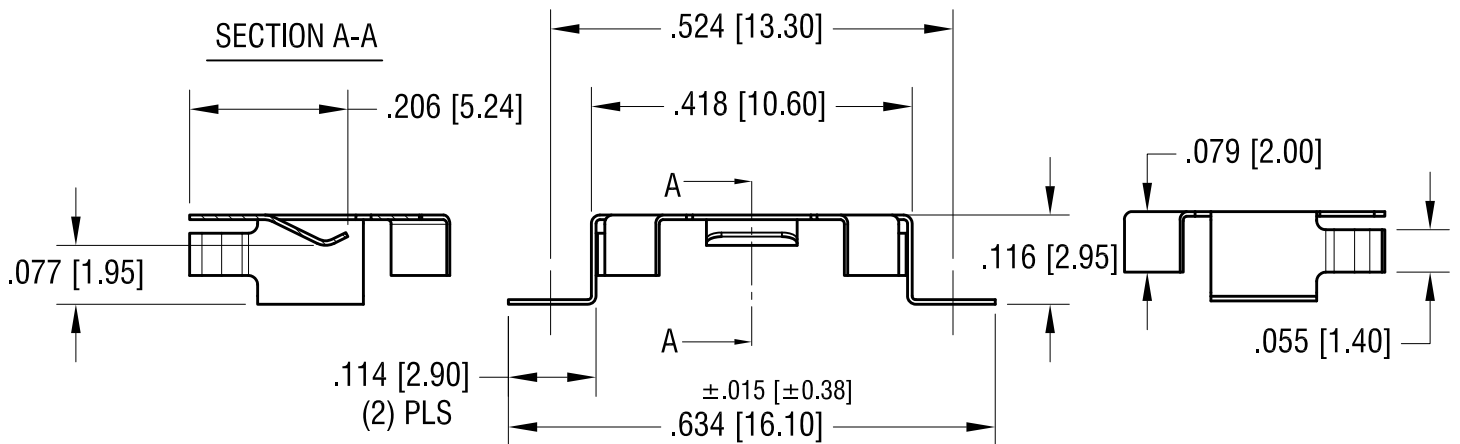

KEYSTONE ELECTRONICS CORP.

www.keyelco.com • ASTORIA, N.Y. 11105-2017 • Tel (718) 956-8900

| | | | |
|----------------------------|--------|----------------------------------|-------------|
| PART NAME | | 10mm SM COIN CELL CLIP | |
| MATERIAL | | .006 [0.15] TH'K PHOSPHOR BRONZE | |
| FINISH | DRN BY | DATE | |
| TIN NICKEL PLATE | NT | 9.17.10 | |
| | APP'D | SCALE | |
| | RH | 4X | |
| TOLERANCES | INCH | [MM] | CODE |
| DECIMAL | ±.010 | [±0.25] | C |
| ANGULAR | ± 1° | | |
| UNLESS OTHERWISE SPECIFIED | | | DWG NO. |
| | | | 3030 |

| | | |
|---------|--------------------------|------|
| 5.07.15 | CHANGE AS PER ECN 15-054 | A |
| DATE | DESCRIPTION | REV. |