

THIS DOCUMENT IS THE PROPERTY OF  
KEYSTONE ELECTRONICS CORP. AND  
SHALL NOT BE REPRODUCED, DISTRIBUTED  
OR USED AS A BASIS FOR MANUFACTURE  
WITHOUT PRIOR WRITTEN PERMISSION  
FROM KEYSTONE ELECTRONICS CORP.

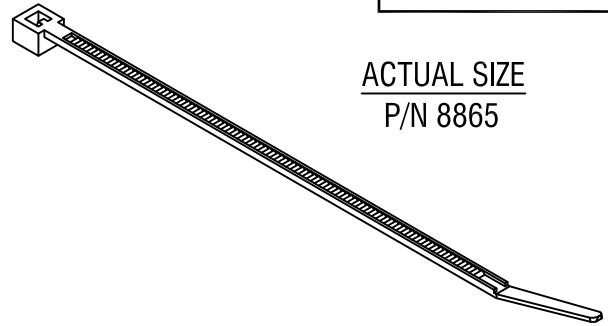

ACTUAL SIZE  
P/N 8865

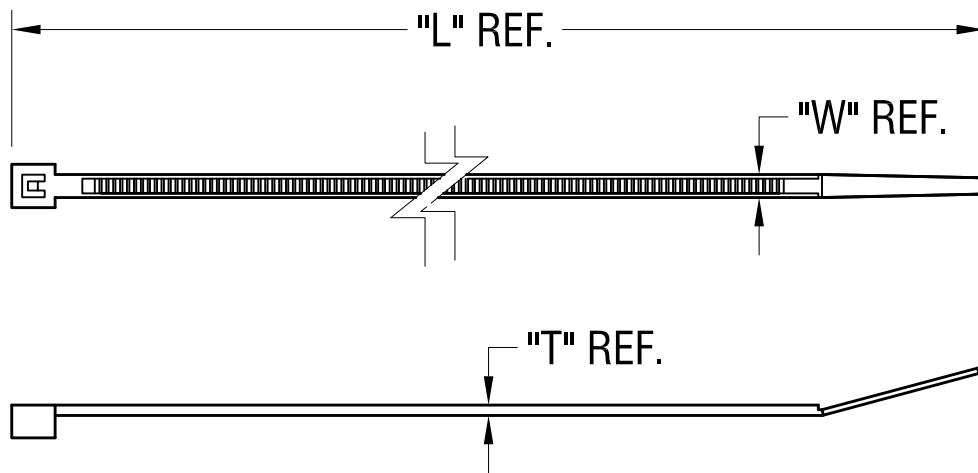

| PART NO. | TENSILE STRENGTH (MIN. BUNDLE) | FOR BUNDLE DIA. (MAX.) | 'L' DIM. REF.   | 'W' DIM. REF. | 'T' DIM. REF. |
|----------|--------------------------------|------------------------|-----------------|---------------|---------------|
| 8865     | 18 lbs                         | 1.000 [25.4]           | 4.250 [107.95]  | .100 [2.54]   | .045 [1.14]   |
| 8866     | 18 lbs                         | 2.000 [50.8]           | 8.000 [203.20]  | .140 [3.56]   | .045 [1.14]   |
| 8867     | 40 lbs                         | 1.250 [31.80]          | 6.000 [152.40]  | .140 [3.56]   | .050 [1.27]   |
| 8868     | 50 lbs                         | 1.750 [44.5]           | 7.500 [190.50]  | .190 [4.83]   | .055 [1.40]   |
| 8869     | 120 lbs                        | 4.000 [101.6]          | 14.500 [368.08] | .190 [4.83]   | .055 [1.40]   |

**KEYSTONE ELECTRONICS CORP.**

www.keyelco.com • NEW HYDE PARK NY 11040 • Tel (516)328-7500

|            |                 |        |                            |                           |         |
|------------|-----------------|--------|----------------------------|---------------------------|---------|
| PART NAME  |                 |        |                            | CABLE TIE                 |         |
| MATERIAL   |                 |        |                            | NATURAL NYLON 6/6 UL94V-2 |         |
| FINISH     |                 | DRN BY | BOONE                      | DATE                      | 11.7.95 |
| -          |                 | APP'D  | RH                         | SCALE                     | 1.2X    |
| TOLERANCES | INCH [MM]       | CODE   | DWG NO.                    |                           |         |
| DECIMAL    | ± .005 [± 0.13] | C      | 8865 - 8869                |                           |         |
| ANGULAR    | ± 1°            |        | UNLESS OTHERWISE SPECIFIED |                           |         |

|         |   |      |
|---------|---|------|
| 8.29.23 | 'W' DIM. REF. FOR P/N 8866 WAS .100<br>CHANGE AS PER ECN 23-149 | C    |
| 7.31.23 | CHANGE AS PER ECN 23-127  | B    |
| 9.10.99 | CHANGE AS PER ECN 99-063  | A    |
| DATE    | DESCRIPTION   | REV. |